



Simply Better Connections

UCE32100

4-Port USB 2.0 Cat 5
Extender (100m)
User Manual

Compliance Statements

FEDERAL COMMUNICATIONS COMMISSION INTERFERENCE STATEMENT

This equipment has been tested and found to comply with the limits for a Class A digital device, pursuant to Part 15 of the FCC Rules. These limits are designed to provide reasonable protection against harmful interference when the equipment is operated in a commercial environment. This equipment generates, uses, and can radiate radio frequency energy and, if not installed and used in accordance with the instruction manual, may cause harmful interference to radio communications. Operation of this equipment in a residential area is likely to cause harmful interference in which case the user will be required to correct the interference at his own expense.

The device complies with Part 15 of the FCC Rules. Operation is subject to the following two conditions: (1) this device may not cause harmful interference, and (2) this device must accept any interference received, including interference that may cause undesired operation.

FCC Caution

Any changes or modifications not expressly approved by the party responsible for compliance could void the user's authority to operate this equipment.

Warning

Operation of this equipment in a residential environment could cause radio interference.

Achtung

Der Gebrauch dieses Geräts in Wohnumgebung kann Funkstörungen verursachen.



KCC Statement

유선 제품용 / A 급 기기 (업무용 방송 통신 기기)
이 기기는 업무용 (A 급) 전자파적합기기로서 판매자 또는 사용자는 이
점을 주의하시기 바라며, 가정 외의 지역에서 사용하는 것을 목적으로
합니다.

Industry Canada Statement

This Class A digital apparatus complies with Canadian ICES-003.

CAN ICES-003 (A) / NMB-003 (A)

RoHS

This product is RoHS compliant.

User Information

Online Registration

Be sure to register your product at our online support center:

International	http://eservice.aten.com
---------------	---

Telephone Support

For telephone support, call this number:

International	886-2-8692-6959
China	86-400-810-0-810
Japan	81-3-5615-5811
Korea	82-2-467-6789
North America	1-888-999-ATEN ext 4988 1-949-428-1111

User Notice

All information, documentation, and specifications contained in this manual are subject to change without prior notification by the manufacturer. The manufacturer makes no representations or warranties, either expressed or implied, with respect to the contents hereof and specifically disclaims any warranties as to merchantability or fitness for any particular purpose. Any of the manufacturer's software described in this manual is sold or licensed *as is*. Should the programs prove defective following their purchase, the buyer (and not the manufacturer, its distributor, or its dealer), assumes the entire cost of all necessary servicing, repair and any incidental or consequential damages resulting from any defect in the software.

Product Information

For information about all ATEN products and how they can help you connect without limits, visit ATEN on the Web or contact an ATEN Authorized Reseller. Visit ATEN on the Web for a list of locations and telephone numbers:

International	http://www.aten.com
North America	http://www.aten-usa.com

Package Contents

Check to make sure that all the components are in working order. If you encounter any problem, please contact your dealer.

1 UCE32100T USB 2.0 CAT 5 Transmitter

1 UCE32100R USB 2.0 CAT 5 Receiver

1 USB 2.0 Type-A Male to Type-B Male Cable

1 Power Adapter

1 Power Cord

4 Mounting Kit

2 Din Rail

2 DC Jack Lock Kit

2 Rubber Feet Sets

1 User Instructions

Table of Contents

Compliance Statements	ii
User Information	iv
Online Registration	iv
Telephone Support	iv
User Notice	iv
Product Information	v
Package Contents	vi
Table of Contents	vii
About this Manual	viii
Conventions	ix
1. Introduction	
Overview	1
Features	2
Supported Operating System	2
Components	3
UCE32100T	3
UCE32100R	4
2. Hardware Setup	
Securing DC Jack	5
Mounting the UCE32100 Units	8
Mounting the UCE32100 Units	8
Wall Mounting the UCE32100 Units	8
DIN Rail Mounting the UCE32100 Units	9
Connecting the UCE32100 Unit	9
3. Operation	
LED Behavior	11
UCE32100T	11
UCE32100R	11
Appendix	
Safety Instructions	13
General	13
Technical Support	15
International	15
North America	15
Specifications	16
ATEN Standard Warranty Policy	17

About this Manual

This user manual is provided to help you get the most from the UCE32100 unit. It covers all aspects of installation, configuration, and operation. An overview of the information found in the manual is provided below.

Chapter 1, Introduction introduces you to the UCE32100 4-Port USB 2.0 CAT 5 Extender (100m). Its purpose, features, and panel components are presented and described.

Chapter 2, Hardware Setup describes the steps that are necessary to quickly and safely set up your installation.

Chapter 3, Operation explains the LED behaviors of the UCE32100 units.

Appendix provides a list of safety instructions and precautions, contact information for ATEN technical support, product specifications, and other technical information.

Note:

- ◆ Read this manual thoroughly and follow the installation and operation procedures carefully to prevent any damage to the unit or any connected devices.
 - ◆ The product may be updated, with features and functions added, improved or removed since the release of this manual. For an up-to-date UCE32100 documentation, visit <http://www.aten.com/global/en/>
-

Conventions

This manual uses the following conventions:

- | | |
|---|--|
| <code>Monospaced</code> | Indicates text that you should key in. |
| [] | Indicates keys you should press. For example, [Enter] means to press the Enter key. If keys need to be chorded, they appear together in the same bracket with a plus sign between them: [Ctrl+Alt]. |
| 1. | Numbered lists represent procedures with sequential steps. |
| ◆ | Bullet lists provide information, but do not involve sequential steps. |
| > | Indicates selecting the option (on a menu or dialog box, for example), that comes next. For example, Start > Run means to open the <i>Start</i> menu, and then select <i>Run</i> . |
|  | Indicates critical information. |

This Page Intentionally Left Blank

Chapter 1

Introduction

Overview

The UCE32100 is a two-units 4-port USB 2.0 CAT 5 Extender that serves as a Transmitter and a Receiver. It provides a durable, high quality connection that harnesses the full capability of the USB2.0 standard to ensure reliable data communication.

The UCE32100 can extend the USB transmission distance up to 100 meters from your computer via an Ethernet cable. The power supply at the UCE32100 receiver unit helps to provide sufficient power to any type of USB device, such as POS, flash drives, webcams, scanners, or printers, etc.

A true plug-and-play solution, the UCE32100 is compatible with all leading operating systems. With its durable metal housing, this high-quality USB extender provides a fast and flexible solution for industrial applications. In addition, its compact size with easy wall mount design and DIN rail included provides space-saving installation.

Features

- ◆ True USB 2.0 transparent extension over Ethernet cabling up to 100 meters
- ◆ Supports all USB 2.0 devices up to 480 Mbps
- ◆ USB Lossless - Higher compatibility of remote USB devices
- ◆ An integrated four port hub allows for extension up to four USB devices without the need for an additional hub
- ◆ Power supply for receiver to ensure power delivery to multiple devices at once
- ◆ Compact size with wall mounting and DIN rail included for flexible installation
- ◆ DC jack lock kit included to ensure durable power adapter connection
- ◆ Supports Windows[®], OS X[®], and Linux[®]
- ◆ Plug-and-play

Supported Operating System

The UCE32100 supports computers using the following operating systems.

Operating System		Version
Windows		XP, 7, 8, 8.1, 10
Linux	RedHat	6.0 or later
	SuSE	8.2 or later
Mac		OS 10.6 or later

Components

UCE32100T

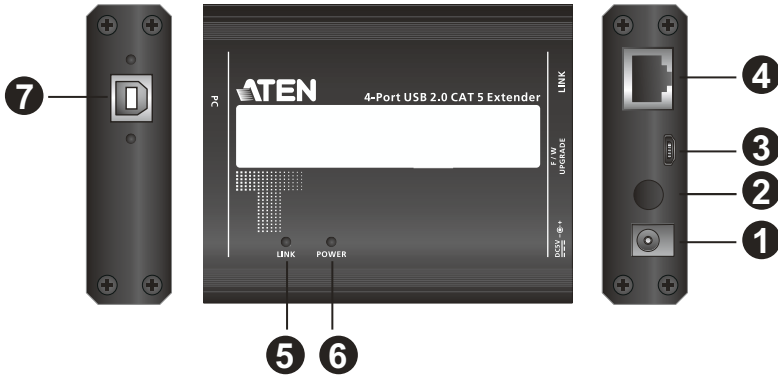

No.	Component	Description
1	power jack	Receives the power adapter. Note: The power adapter is not required but can be connected to the unit to provide power if the USB port on the host PC is not capable of delivering 500mA to the unit.
2	DC jack lock	Locks the power jack to avoid power cut or power shortage.
3	firmware upgrade port (Micro USB)	This port is for firmware upgrade.
4	link port (RJ-45)	Receives an Ethernet cable that sends and transmits data between the UCE32100T and the UCE32100R.
5	link LED (amber)	<ul style="list-style-type: none"> ◆ On: To indicate that the USB connection between the UCE32100T and the UCE32100R is stable. ◆ Blink: To indicate that the data is being transmitted between the UCE32100T and the UCE32100R. ◆ Off: To indicate there is no connection between the UCE32100T and the UCE32100R.
6	power LED (green)	<ul style="list-style-type: none"> ◆ On: To indicate that the power is being supplied to the unit. ◆ Off: To indicate that there is no power being supplied to the unit.
7	USB 2.0 Type-B female port (host)	Receives a USB Type-B male to Type-A male cable that connects the UCE32100T to the computer in your setup.

UCE32100R

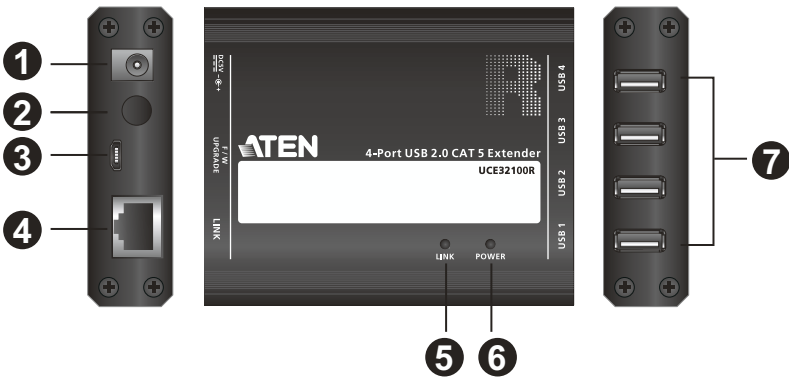

No.	Component	Description
1	power jack	Receives the power adapter.
2	DC jack lock	Locks the power jack to avoid power cut or power shortage.
3	firmware upgrade port (Micro USB)	This port is for firmware upgrade.
4	link Port (RJ-45)	Receives an Ethernet cable that sends and transmits data between the UCE32100R and the UCE32100T.
5	link LED (amber)	<ul style="list-style-type: none"> ◆ On: To indicate that the USB connection between the UCE32100T and the UCE32100R is stable. ◆ Blink: To indicate that the data is being transmitted between the UCE32100T and the UCE32100R. ◆ Off: To indicate there is no connection between the UCE32100T and the UCE32100R.
6	power LED (green)	<ul style="list-style-type: none"> ◆ On: To indicate that the power is being supplied to the unit. ◆ Off: To indicate that there is no power being supplied to the unit.
7	USB 2.0 Type-A female ports (USB peripherals)	Receive USB cables to connect to USB peripherals you wish to access from the computer in your setup.

Chapter 2

Hardware Setup



Please review the safety information regarding the placement of this device in *Safety Instructions*, page 13.

Securing DC Jack

Use the DC jack lock kit provided with the package to secure the power adapter to avoid power cut or power shortage.

To secure the DC jack lock onto the UCE32100 units, follow the steps below.

1. Remove the rubber mat from the UCE32100 unit.

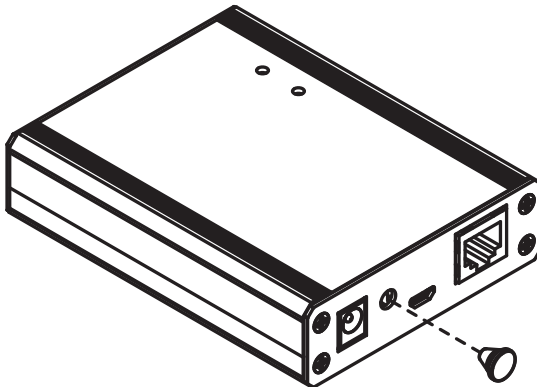

2. Insert the DC jack lock component A into the hole as pictured below.

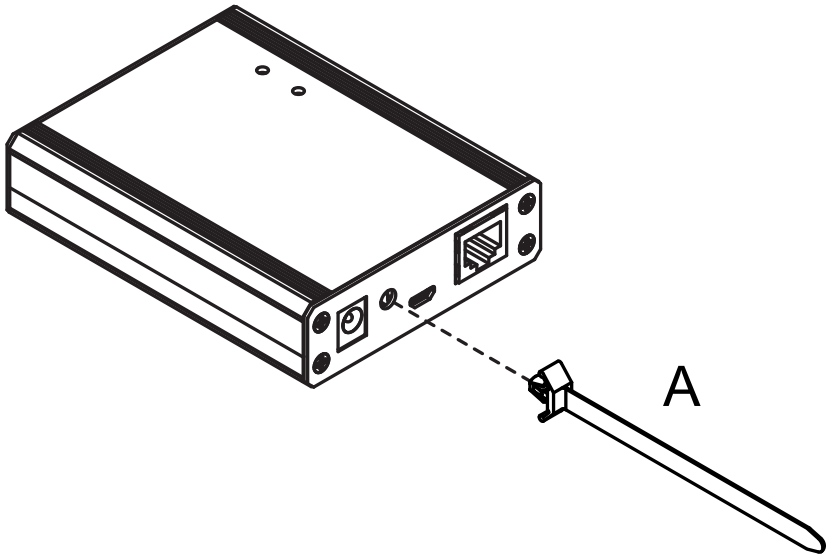

3. Insert the other end of the DC jack lock component A through the component B's joint.

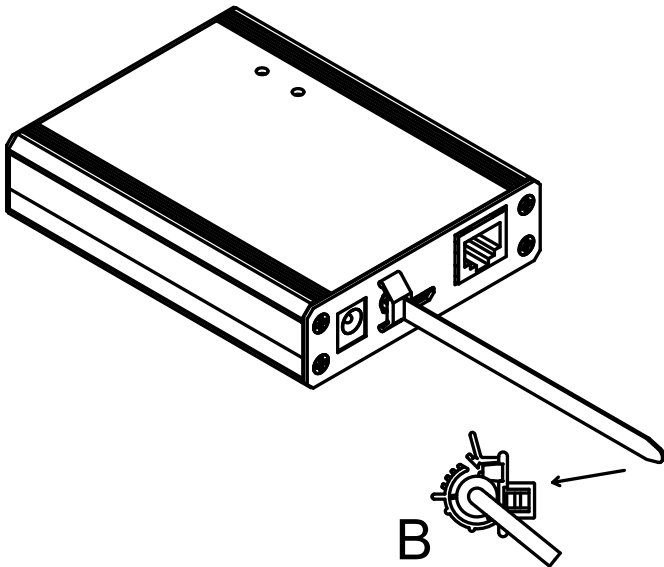

4. Connect the power adapter through the DC jack lock component B's joint as pictured below.

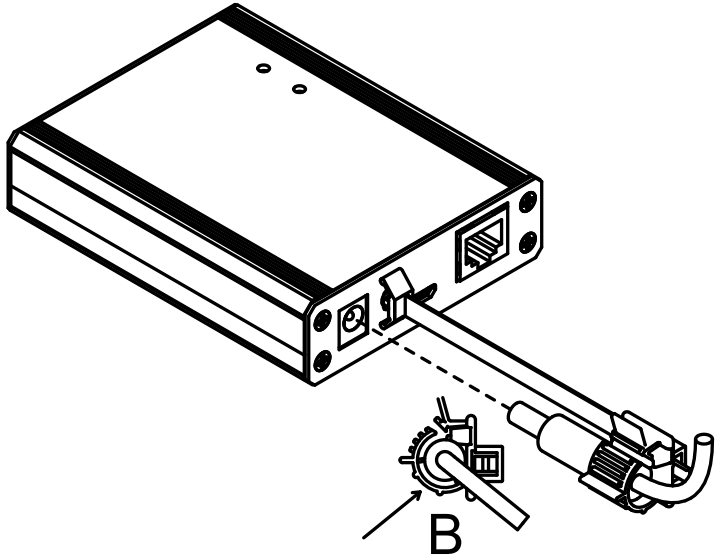

5. Now the DC jack lock is secured on the UCE32100 unit.

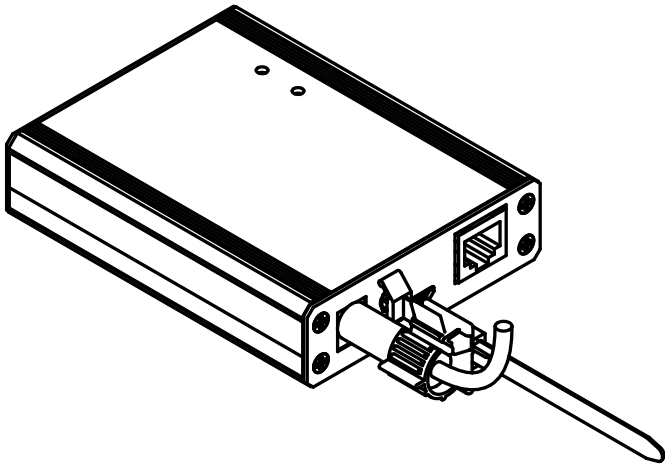

6. Repeat step 1 to step 5 for the second UCE32100 unit.

Mounting the UCE32100 Units

You can mount the UCE32100 units to the wall or on the DIN Rail. Before you begin to mount the units, you will need to mount the brackets into the back of the UCE32100 units.

Mounting the UCE32100 Units

Screw the mounting brackets into the back of the units using the smaller screws supplied in the Mounting Kit.

Note: If you do not use the supplied screws, the length of the shank (the threaded portion) must not exceed 4.50mm.

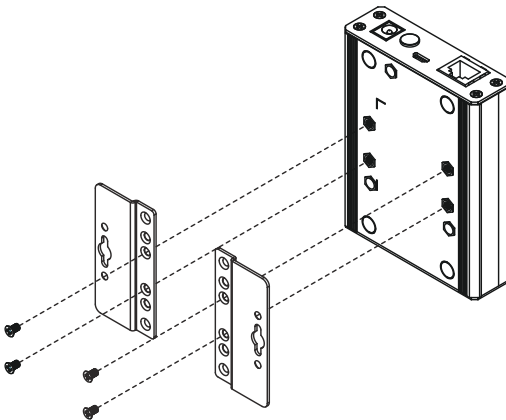

Wall Mounting the UCE32100 Units

Screw the mounting brackets to a wall.

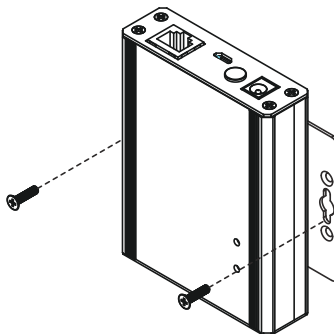

DIN Rail Mounting the UCE32100 Units

1. Screw the DIN rail brackets to the mounting brackets using the larger screws supplied with the Mounting Kit.
2. Hang the UCE32100 units on the DIN rail.

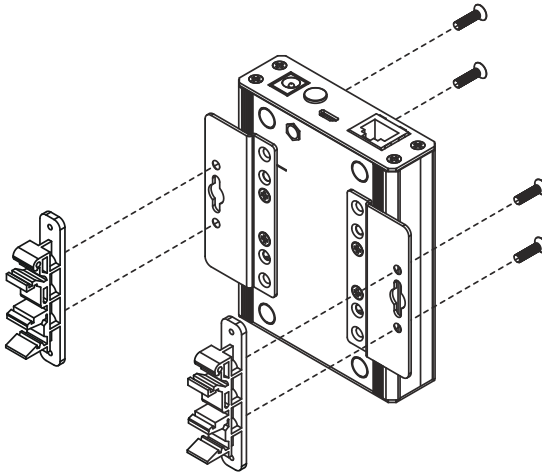

Connecting the UCE32100 Unit

Follow the steps below to connect the UCE32100 units.

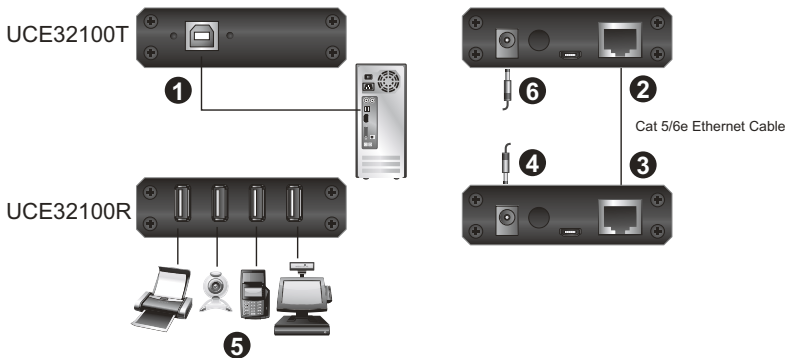

1. Connect the UCE32100T's USB Type-B port to a USB port on the computer using a USB 2.0 cable.
2. Connect one end of an Ethernet cable (cable length up to 100 meters) to UCE32100T's link port.
3. Connect the other end of the Ethernet cable to the UCE32100R's link port.
4. Plug the power adapter (included with this package) into an AC source and plug the other end into the UCE32100R's power jack.
5. Connect up to four USB 2.0/3.0 peripheral devices to UCE32100R's USB Type-A ports.
6. If you need additional power supply for the UCE32100T, plug the power adapter (not included with this package, may need additional purchase) into an AC source and plug the other end into the UCE32100T's power jack.

Chapter 3 Operation



Please review the safety information regarding the placement of this device in *Safety Instructions*, page 13.

LED Behavior

UCE32100T

LED Behavior	Status	
Power LED	Off	No power connected
	On	The extender is powered
Link LED	Off	No link established
	On	Link established with the Receiver
	Flash	Data transmission

UCE32100R

LED Behavior	Status	
Power LED	Off	No power connected
	On	The extender is powered
Link LED	Off	No link established
	On	Link established with the Transmitter
	Flash	Data transmission

This Page Intentionally Left Blank

Safety Instructions

General

- ◆ This product is for indoor use only.
- ◆ Read all of these instructions. Save them for future reference.
- ◆ Follow all warnings and instructions marked on the device.
- ◆ Do not place the device on any unstable surface (cart, stand, table, etc.). If the device falls, serious damage will result.
- ◆ Do not use the device near water.
- ◆ Do not place the device near, or over, radiators or heat registers.
- ◆ The device cabinet is provided with slots and openings to allow for adequate ventilation. To ensure reliable operation, and to protect against overheating, these openings must never be blocked or covered.
- ◆ The device should never be placed on a soft surface (bed, sofa, rug, etc.) as this will block its ventilation openings. Likewise, the device should not be placed in a built in enclosure unless adequate ventilation has been provided.
- ◆ Never spill liquid of any kind on the device.
- ◆ Unplug the device from the wall outlet before cleaning. Do not use liquid or aerosol cleaners. Use a damp cloth for cleaning.
- ◆ The device should be operated from the type of power source indicated on the marking label. If you are not sure of the type of power available, consult your dealer or local power company.
- ◆ To prevent damage to your installation it is important that all devices are properly grounded.
- ◆ Do not allow anything to rest on the power cord or cables. Route the power cord and cables so that they cannot be stepped on or tripped over.
- ◆ Position system cables and power cables carefully; Be sure that nothing rests on any cables.
- ◆ Never push objects of any kind into or through cabinet slots. They may touch dangerous voltage points or short out parts resulting in a risk of fire or electrical shock.
- ◆ Do not attempt to service the device yourself. Refer all servicing to qualified service personnel.

- ◆ If the following conditions occur, unplug the device from the wall outlet and bring it to qualified service personnel for repair.
 - ◆ The power cord or plug has become damaged or frayed.
 - ◆ Liquid has been spilled into the device.
 - ◆ The device has been exposed to rain or water.
 - ◆ The device has been dropped, or the cabinet has been damaged.
 - ◆ The device exhibits a distinct change in performance, indicating a need for service.
 - ◆ The device does not operate normally when the operating instructions are followed.
- ◆ Only adjust those controls that are covered in the operating instructions. Improper adjustment of other controls may result in damage that will require extensive work by a qualified technician to repair.

Technical Support

International

- ◆ For online technical support – including troubleshooting, documentation, and software updates: <http://support.aten.com>
- ◆ For telephone support, see *Telephone Support*, page iv:

North America

Email Support		support@aten-usa.com
Online Technical Support	Troubleshooting Documentation Software Updates	http://www.aten-usa.com/support
Telephone Support		1-888-999-ATEN ext 4988 1-949-428-1111

When you contact us, please have the following information ready beforehand:

- ◆ Product model number, serial number, and date of purchase
- ◆ Your computer configuration, including operating system, revision level, expansion cards, and software
- ◆ Any error messages displayed at the time the error occurred
- ◆ The sequence of operations that led up to the error
- ◆ Any other information you feel may be of help

Specifications

Function		UCE32100T	UCE32100R
Connectors	USB Port	1 x USB Type-B Female 1 x Micro USB Female (Firmware Upgrade)	4 x USB Type-A Female 1 x Micro USB Female (Firmware Upgrade)
	USB Link	1 x RJ-45 Female	
	Power	1 x DC Jack	
USB Specification		USB 2.0 High-Speed	
USB Devices Support		N/A	4 USB devices
Maximum USB devices can support		N/A	15
Cable Type		Ethernet Cable	
Signal Range		100 m	
LEDs	Status	2 x LED	
Power Consumption		Bus-powered	Self-powered
Environmental	Operating Temperature	0–50°C	
	Storage Temperature	-20–70°C	
	Humidity	-20% – 80% RH, Non-condensing	
Physical Properties	Housing	Metal	
	Weight	0.21 kg (0.46lb)	
	Dimensions (L x W x H)	10.15 x 7.90 x 2.44 cm (4 x 3.11 x 0.96 in.)	

Note: For best performance, the maximum number of single devices that the UCE32100 can support are listed below:

- ◆ HID USB devices is 15 (hub included)
- ◆ 720P USB Camera is 1
- ◆ 1080P USB Camera is 1
- ◆ USB Disk is 10 (hub included)
- ◆ USB Audio is 10 (hub included)

ATEN Standard Warranty Policy

Limited Hardware Warranty

ATEN warrants its hardware in the country of purchase against flaws in materials and workmanship for a Warranty Period of two [2] years (warranty period may vary in certain regions/countries) commencing on the date of original purchase. This warranty period includes the LCD panel of ATEN LCD KVM switches. For UPS products, the device warranty is two [2] years but battery is one [1] year. Select products are warranted for an additional year (see *A+ Warranty* for further details). Cables and accessories are not covered by the Standard Warranty.

What is covered by the Limited Hardware Warranty

ATEN will provide a repair service, without charge, during the Warranty Period. If a product is defective, ATEN will, at its discretion, have the option to (1) repair said product with new or repaired components, or (2) replace the entire product with an identical product or with a similar product which fulfills the same function as the defective product. Replaced products assume the warranty of the original product for the remaining period or a period of 90 days, whichever is longer. When the products or components are replaced, the replacing articles shall become customer property and the replaced articles shall become the property of ATEN.

To learn more about our warranty policies, please visit our website:

<http://www.aten.com/global/en/legal/policies/warranty-policy>

© Copyright 2023 ATEN® International Co., Ltd.
Released: 2023-10-16

ATEN and the ATEN logo are registered trademarks of ATEN International Co., Ltd. All rights reserved. All other brand names and trademarks are the registered property of their respective owners.