

**4 Console / 8 Port
KVM Switch**
CS428
User Manual



FCC Information

This is an FCC Class A product. In a domestic environment this product may cause radio interference in which case the user may be required to take adequate measures.

This equipment has been tested and found to comply with the limits for a Class A digital device, pursuant to Part 15 of the FCC Rules. These limits are designed to provide reasonable protection against harmful interference when the equipment is operated in a commercial environment. This equipment generates, uses and can radiate radio frequency energy and, if not installed and used in accordance with the instruction manual, may cause harmful interference to radio communications. Operation of this equipment in a residential area is likely to cause harmful interference in which case the user will be required to correct the interference at his own expense.

RoHS

This product is RoHS compliant.

SJ/T 11364-2006

The following contains information that relates to China.

部件名称	有毒有害物质或元素					
	铅	汞	镉	六价铬	多溴联苯	多溴二苯醚
电器部件	●	○	○	○	○	○
机构部件	○	○	○	○	○	○

- : 表示该有毒有害物质在该部件所有均质材料中的含量均在SJ/T 11363-2006规定的限量要求之下。
- : 表示符合欧盟的豁免条款, 但该有毒有害物质至少在该部件的某一均质材料中的含量超出SJ/T 11363-2006的限量要求。
- ×: 表示该有毒有害物质至少在该部件的某一均质材料中的含量超出SJ/T 11363-2006的限量要求。



User Information

Online Registration

Be sure to register your product at our online support center:

- ◆ International – <http://support.aten.com>
- ◆ North America – http://www.aten-usa.com/product_registration

Telephone Support

- ◆ International – 886-2-8692-6959
- ◆ North America – 1-888-999-ATEN

User Notice

All information, documentation, and specifications contained in this manual are subject to change without prior notification by the manufacturer. The manufacturer makes no representations or warranties, either expressed or implied, with respect to the contents hereof and specifically disclaims any warranties as to merchantability or fitness for any particular purpose. Any of the manufacturer's software described in this manual is sold or licensed `as is'. Should the programs prove defective following their purchase, the buyer (and not the manufacturer, its distributor, or its dealer), assumes the entire cost of all necessary servicing, repair and any incidental or consequential damages resulting from any defect in the software.

The manufacturer of this system is not responsible for any radio and/or TV interference caused by unauthorized modifications to this device. It is the responsibility of the user to correct such interference.

The manufacturer is not responsible for any damage incurred in the operation of this system if the correct operational voltage setting was not selected prior to operation. PLEASE VERIFY THAT THE VOLTAGE SETTING IS CORRECT BEFORE USE.

Package Contents

The basic CS428 package consists of:

- ◆ 1 CS428 KVM Switch
- ◆ 2 KVM Cable Sets (2L-1701S)
- ◆ 1 Power Adapter
- ◆ 1 Rack Mount Kit
- ◆ 1 User Manual*

Check to make sure that all the components are present and that nothing got damaged in shipping. If you encounter a problem, contact your dealer.

Read this manual thoroughly and follow the installation and operation procedures carefully to prevent any damage to the unit, and/or any of the devices connected to it.

* Features may have been added to the CS428 since this manual was printed. Please visit our website to download the most up to date version of the manual.

© Copyright 2008 ATEN® International Co., Ltd.
Manual Part No. PAPE-0167-300G
Manual Date: 2008-08-25

ATEN and the ATEN logo are registered trademarks of ATEN International Co., Ltd. All rights reserved.
All other brand names and trademarks are the registered property of their respective owners.

Contents

FCC Information	ii
RoHS	ii
SJ/T 11364-2006	ii
User Information	iii
Online Registration	iii
Telephone Support	iii
User Notice	iii
Package Contents	iv
About this Manual	vii
Conventions	viii
Product Information	viii
1. Introduction	
Overview	1
Features	2
Requirements	3
Console	3
Computers	3
Cables	3
Components	4
Front Panel	4
Rear Panel	5
2. Hardware Setup	
Stacking and Mounting	7
Stacking	7
Rack Mounting	7
Single Station Installation	8
Cascaded Installation	9
3. Basic Operation	
Hot Plugging	11
Powering Off and Restarting	11
Port Numbering	12
Port Selection	12

4. OSD Operation

OSD Overview	13
OSD Navigation	15
OSD Main Menu Headings	16
OSD Functions	16
F1 HELP:.....	16
F2 EDIT:	17
F3 LIST:	18
F4 SCAN:	19
F5 ADM:	20
F6 Set:.....	22
F7 QV	24
F8 Out.....	24

5. Appendix

Safety Instructions	25
General	25
Rack Mounting	27
Technical Support	28
International	28
North America	28
Master View - Computer Connection Tables	29
Specifications	30
OSD Factory Default Settings	31
Power On Self Test	31
Troubleshooting	32
Limited Warranty	32

About this Manual

This User Manual is provided to help you get the most from your *c/c* system. It covers all aspects of installation, configuration and operation. An overview of the information found in the manual is provided below.

Chapter 1, Introduction, introduces you to the CS428 system. Its purpose, features and benefits are presented, and its front and back panel components are described.

Chapter 2, Hardware Setup, describes how to set up your installation. The necessary steps – from a basic single stage hookup to a complete 32 switch cascaded operation are provided.

Chapter 3, Basic Operation, explains the fundamental concepts involved in operating the CS428.

Chapter 4, OSD Operation, provides a complete description of the CS428's OSD (On Screen Display), and how to work with it.

An Appendix, provides specifications and other technical information regarding the CS428.

Conventions

This manual uses the following conventions:

- Monospaced Indicates text that you should key in.
- [] Indicates keys you should press. For example, [Enter] means to press the **Enter** key. If keys need to be chorded, they appear together in the same bracket with a plus sign between them: [Ctrl+Alt].
1. Numbered lists represent procedures with sequential steps.
- ◆ Bullet lists provide information, but do not involve sequential steps.
- Indicates selecting the option (on a menu or dialog box, for example), that comes next. For example, Start → Run means to open the *Start* menu, and then select *Run*.
-  Indicates critical information.

Product Information

For information about all ATEN products and how they can help you connect without limits, visit ATEN on the Web or contact an ATEN Authorized Reseller. Visit ATEN on the Web for a list of locations and telephone numbers

- ◆ International – <http://www.aten.com>
- ◆ North America – <http://www.aten-usa.com>

Chapter 1

Introduction

Overview

The CS-428 KVM Switch is a control unit that allows four independent keyboard, mouse, and monitor Consoles to access eight computers, either independently or on a multiuser shared basis, in a convenient, cost effective manner. A Master View CS-428 unit can control up to 8 PCs. Since it can be cascaded one level down to a CS-138A, CS-9138, CS-128A, or CS-124A, up to 9 Master View units (the CS-428 plus eight cascaded ones), can control up to 64 computers from any of the four Consoles.

Setup is fast and easy; plugging cables into their appropriate ports is all that is entailed. There is no software to configure, so there is no need to get involved in complex software installation routines or be concerned with incompatibility problems. Because the CS-428 intercepts keyboard input directly, it works on any hardware platform and with all operating systems.

The CS-428 provides a convenient OSD (On Screen Display), function that allows any of the four Consoles to access any computer connected to the system by means of an on screen, menu driven interface. In addition, a powerful *Quick View Scan* feature allows you to auto scan and monitor the activities of all operating computers on the installation one by one.

For security, two level password protection (administrator and user), is provided in order to prevent unauthorized access to the computers. Responding to the growing use of audio input/output in the workstation space, the CS-428 has been designed with built in microphone and speaker support, as well.

There is no better way to save time and money than with a Master View CS-428 installation. By allowing all the attached computers to be managed from four separate Consoles, a Master View CS-428 installation: (1) eliminates the expense of having to purchase a separate keyboard, monitor, and mouse for each computer; (2) saves all the space those extra components would take up; (3) saves on energy costs; and (4) eliminates the inconvenience and wasted effort involved in constantly moving around from one computer to another, while allowing a single user to access the computers from several different convenient locations, or up to four users to share them.

Features

- ◆ 4 Consoles Control 8 Computers
- ◆ Up to four users can operate up to 64 computers (via cascading to CS-138A, CS-9138, CS-128A, or CS-124A) at the same time
- ◆ Each console has its own access control
- ◆ Two level password security (one Administrator; four User passwords)
- ◆ Administrator can access any computer completely independently of the other users
- ◆ Each User has his own access control list
- ◆ Port selection via OSD (On Screen Display)
- ◆ Auto expansion of the OSD port list for cascaded installations
- ◆ OSD automatically adjusts to resolution changes
- ◆ Hot Pluggable - add or remove any computer without powering off the switch
- ◆ Auto Scan function provides easy monitoring of all computers
- ◆ Supports 1920 x 1440 resolution; DDC2 (Display Data Channel 2)
- ◆ PS/2 compatible mouse support: Microsoft Intellimouse Pro, Logitech FirstMouse, FirstMouse+, support*
- ◆ Audio (microphone and speaker) support
- ◆ Special design for easy stacking
- ◆ Rack mountable in 19" (1U) system rack

* PS/2 compatible mouse support is for three button (wheel) mice. The Logitech Mouse Ware program's *Change Device* procedure does not work on Microsoft NT systems.

Requirements

Console

- ◆ A VGA, SVGA, or multisync monitor capable of the highest resolution that you will be using on any computer in the installation.

If a monitor switches to a computer using a resolution that is higher than the resolution that the monitor can support, serious damage to the monitor may result.

- ◆ A PS/2 style mouse
- ◆ A PS/2 style keyboard
- ◆ Microphone and Speakers (Optional)

Computers

The following equipment must be installed on each computer:

- ◆ A VGA, SVGA or multisync card.
- ◆ A 6-pin Mini-DIN (PS/2 style) mouse port.
- ◆ A 6-pin Mini-DIN (PS/2 style) keyboard port with +5V DC on pin 4 and Ground on pin 3.

Cables

Use of substandard cables may damage the connected devices or degrade overall performance. For optimum signal integrity and to simplify the layout, we strongly recommend that you use the following high quality Custom Cable sets:

Connector Type	CS Custom Cable
Consoles 3 and 4	2L-1701S
PS/2 (6 pin mini-DIN) Keyboard and Mouse Ports	2L-1701P
Cascading to Second Stage Master View	2L-1601P

Components

Front Panel

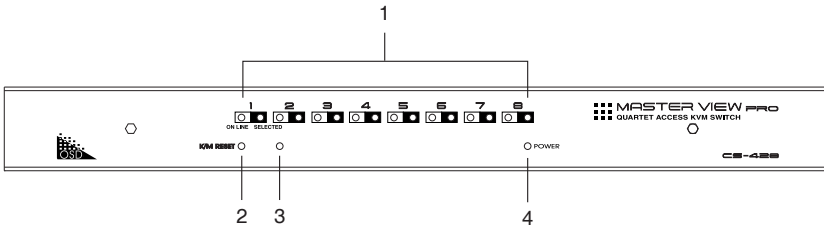

No.	Component	Description
1	Port LEDs	<p>The Port LEDs provide status information about their corresponding Computer Ports. There is one pair of LEDs for each Port. The one on the left is the <i>On Line</i> LED; the one on the right is the <i>Selected Port</i> LED:</p> <ul style="list-style-type: none"> ◆ An <i>On Line</i> LED lights ORANGE to indicate that the computer attached to its corresponding port is up and running. ◆ A <i>Selected</i> LED lights GREEN to indicate that the computer attached to its corresponding port is the one that has the KVM focus.
2	K/M Reset Switch	If the keyboard and mouse get stuck and need to be reset, insert a pointed object in here and push.
3	Sound Opening	System sounds (beeps, etc.), are emitted from this opening.
4	Power LED	Lights BLUE to indicate that the CS-428 has been turned On and is receiving power.

Rear Panel

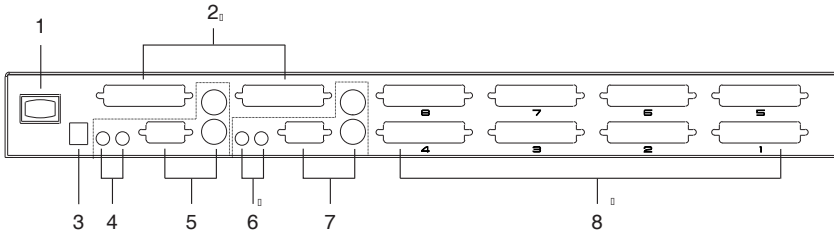

No.	Component	Description
1	Power Switch	A rocker switch to power the system on and off.
2	Console 3 and 4 Connectors	Use KVM Cable sets (see <i>Cables</i> , page 3), to connect the components that make up Consoles 3 and 4 to these ports.
3	Power Jack	The power adapter cable plugs in here.
4	Console 2 Microphone and Speaker Jacks	The microphone and speakers belonging to Console 2 plug in here.
5	Console 2 KVM Connectors	The keyboard, monitor and mouse belonging to Console 2 plug in here.
6	Console 1 Microphone and Speaker Jacks	The microphone and speakers belonging to Console 1 plug in here.
7	Console 1 KVM Connectors	The keyboard, monitor and mouse belonging to Console 1 plug in here.
8	KVM Port Section	Use KVM Cable sets (see <i>Cables</i> , page 3), to connect computers or cascade additional KVM switches (see <i>Cascaded Installation</i> , page 9) to any available port.

This Page Intentionally Left Blank

Chapter 2

Hardware Setup



1. Important safety information regarding the placement of this device is provided on page 25. Please review it before proceeding.
2. Make sure that power to all the devices you will be connecting up have been turned off. You must unplug the power cords of any computers that have the Keyboard Power On function.

Stacking and Mounting

The CS428 can be placed on the desktop or it can be rack mounted, as described in the sections that follow.

Stacking

The unit comes with the stacking brackets already attached. To stack additional units, simply line up the brackets on the top and bottom units, then fit the top unit down onto the bottom unit.

Rack Mounting

The CS428 can be mounted in a 1U system rack. To rack mount the unit, do the following:

1. Remove the stacking brackets by unscrewing them from the unit, as shown in the diagram below:

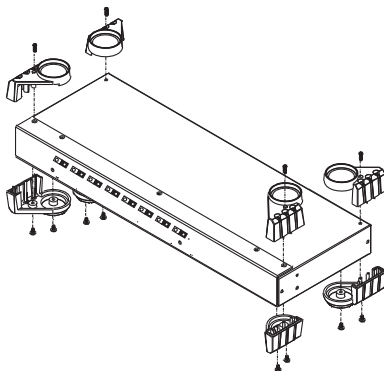

2. Use the screws that came with the rack mount kit to screw the mounting brackets into the sides of the unit, as shown in the diagram below:

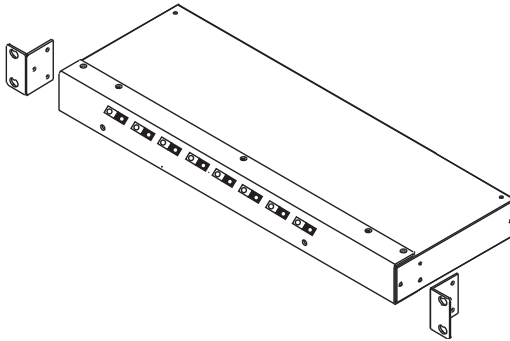

3. Slide the unit into the rack and secure it to the rack.

Single Station Installation

The most basic installation is a Single Stage installation, in which no additional Master Views are cascaded down from the first unit. To set up a single stage installation, refer to the installation diagram on the following page (the numbers in the diagram correspond to the numbers of the steps) as you perform these steps:

1. Plug the keyboard, monitor, mouse microphone and speaker cables for Consoles 1 and 2 into the console port connectors located on the CS428's rear panel. Each port is labeled with an icon to indicate itself.

Note: Use of microphone and speakers is optional.

2. Use the 2L-1701S KVM cable sets included with this package to connect the components that make up Consoles 3 and 4 to Console ports 3 and 4 on the rear panel of the CS428 unit.
3. Use 2L-1701S KVM cable sets (see *Cables*, page 3), to connect any available KVM port to the keyboard, monitor, and mouse ports of the computers you are installing.
4. Plug the power adapter into an AC source; plug the power adapter cable into the 's Power Jack.
5. Turn on the power to the CS428.

Note: When you turn the unit On, it undergoes a Power On Self Test. If there is a problem, Port LEDs 1 - 4 flash repeatedly according to a pattern that indicates what the problem is. See *Power On Self Test*, page 31 for details.

6. Plug in the power cords and power On all the computers.

Note: You must turn on the power to the CS428 before turning on the power to the computers.

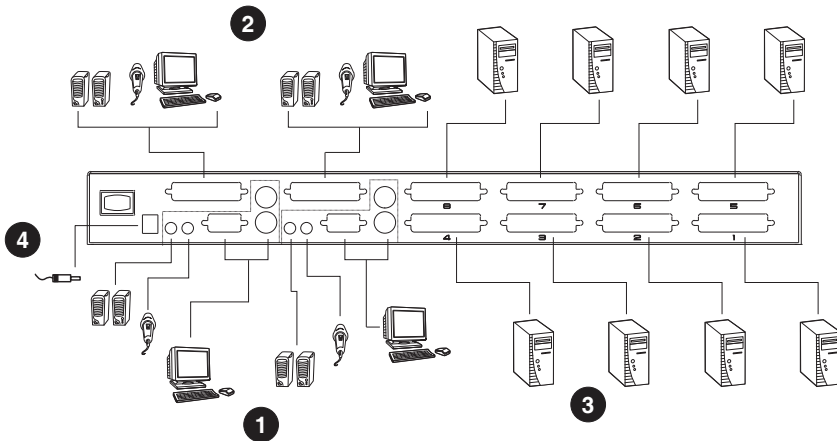

Cascaded Installation

To control even more computers, up to eight additional Master View switches can be cascaded from the KVM ports of the CS428. The cascaded Master Views that connect back to the CS428 (referred to as the First Stage unit), are considered Second Stage units. As many as 64 computers can be controlled in a complete two stage installation. A table showing the relation between the number of computers and the number of Master View units needed to control them is provided on page 29 in the Appendix.

Note: 1. Only Master View CS-138A, CS-9138, CS-128A, or CS-124A switches can be used with the CS428;

2. Switches cannot be cascaded beyond the second stage.
-

To set up a two stage installation, do the following:

1. Make sure that power to all the devices you will be connecting up, including all preexisting devices on the installation, have been turned off (unplug the power cords of any computers that have the *Keyboard Power On* function; unplug the First Stage unit).
2. Use a 2L-1601P KVM Cable set (see *Cables*, page 3), to connect any available KVM port on the CS428 (First Stage unit) to the Console Port connectors of the Second Stage unit.
3. Use KVM Cable sets (see the *Cables* section of the Second Stage unit's user manual for details), to connect any available KVM port on the Second Stage unit to the keyboard, monitor, and mouse ports of the computer you are installing.
4. Repeat steps 1 - 3 for any other Second Stage units you wish to connect.
5. Plug in the power adapter cable for the First Stage Master View unit's Power Jack.
6. For each Second Stage unit, plug the power adapter into an AC source; plug the power adapter cable into the Master View's Power Jack.
7. Power on the First Stage CS428.
8. Power on all Second Stage units
9. Plug in the power cords and power On all the computers.

Note: You must follow the sequence in steps 5 - 9 when powering up.

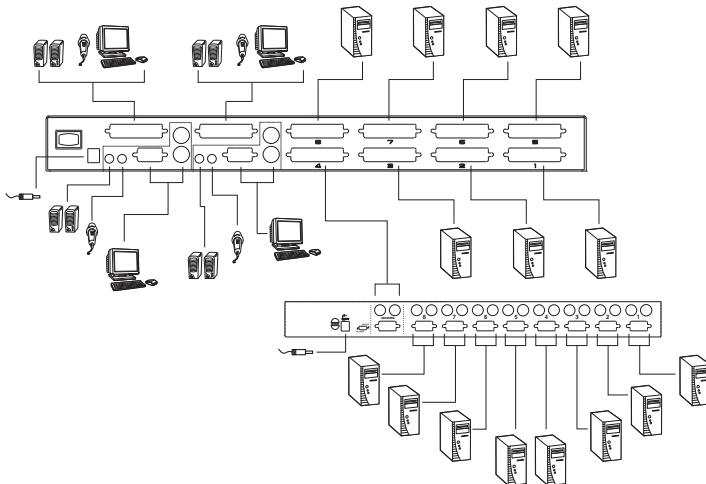

Chapter 3

Basic Operation

Hot Plugging

The Master View CS428 supports hot plugging - components can be removed and added back into the installation by unplugging their cables from the KVM ports without the need to shut the unit down. In order for hot plugging to work properly, however, these procedures must be followed:

1. When hot plugging cables from the KVM ports the cable must be plugged back into the same port it was removed from.
2. You may unplug the mouse and plug it back in again (to reset the mouse, for example), as long as you use the *same* mouse.
3. If there is no response to mouse and/or keyboard after you plug the mouse back in, perform a **K/M Reset** by inserting a thin pointed object into the Reset receptacle on the unit's front panel and gently pushing.

Powering Off and Restarting

If it becomes necessary to Power Off any of the Master View units, before starting it back up you must do the following:

1. Shut down all the computers that are attached to the unit, as well as all the Second Stage Master Views that are cascaded down from it and all the computers that are connected to the stations that you shut down.

Note: You must unplug the power cords of any computers that have the *Keyboard Power On* function that are connected to the shut down Master Views. Otherwise, the switches will still receive power from the computers.

2. Wait 10 seconds, then restart the CS428.

Note: When the CS428 comes up it issues a long beep, and the Consoles are automatically logged out. Each Console logout produces a short beep - so you will hear one long and four short beeps.

3. Restart the Second Stage Master Views.
4. After all the Master View's are up, power On the computers.

Port Numbering

Each computer on the installation is assigned a unique Port Number (PN). The PN is a one or two segment number that is determined by the Stage Level and KVM port of the KVM switch that the computer is connected to. The first segment represents the KVM Port number of the First Stage unit (the CS428); the second segment represents the KVM Port number of the Second Stage unit.

Note: The KVM port numbers are clearly indicated on the back panels of the switches.

For example, a computer connected to KVM port 7 of a First Stage CS428, would have a PN of 7.

A computer connected to a Second Stage cascaded Master View has a two digit PN:

- ♦ The first digit represents the KVM Port of the First Stage Master View (the CS428) that the Second Stage Master View is cascaded down from
- ♦ The second digit represents the KVM Port of the Second Stage unit that the computer is connected to.

For example, a computer with a PN of **2-3** would be connected to KVM Port 3 of a Second Stage unit; which is cascaded down from KVM Port 2 of the CS428.

Port Selection

Instant access to any computer on the installation is provided by the menu driven *On Screen Display* (OSD) function. OSD operation is discussed in the next chapter.

Chapter 4

OSD Operation

OSD Overview

On Screen Display (OSD), provides a menu driven interface to handle the computer switching procedure. All operations start from the OSD Main Menu. To activate the Main Menu, tap either Ctrl key twice.

-
- Note:**
1. The keys must be on the same side (both left, or both right).
 2. If using the Ctrl key conflicts with applications running on the computers, you can optionally change the hotkey to the Scroll Lock key (see *OSD Activating Hotkey* under the **F6 Set** function on page 22), in which case you would press [Scroll Lock] twice.
-

For security purposes, the OSD incorporates a two level (Administrator / User) password system. Before the OSD Main Screen comes up, a window appears that asks you to provide your password. If the password function has been set for the Console you are at, you must provide the password in order to access the OSD Main screen.

If this is the first time that the OSD is being run, or if the password function is not being used, simply press **[Enter]**. The OSD Main Screen comes up in Administrator Mode. In this mode, you have administrator privileges, with access to all User and Administrator functions, and can set up operations (including password authorization for the future), as you would like.

When you invoke the OSD, a screen similar to the one below appears:

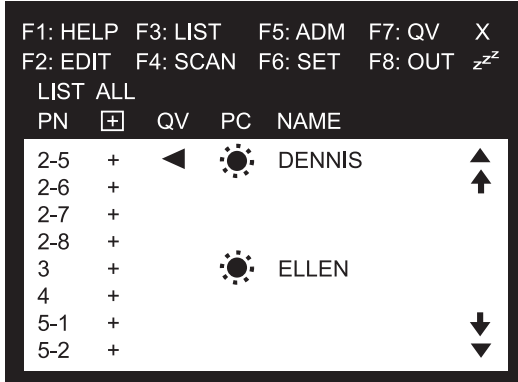

Note: 1. The diagram depicts the Administrator's Main Screen. The User Main Screen does not show the **F2** and **F5** function, since they are reserved for the Administrator and can't be accessed by ordinary Users.

2. The OSD always starts in List view, with the highlight bar at the same position it was in the last time it was closed.

OSD Navigation

- ◆ To dismiss the menu, and deactivate the OSD, Click the **X** at the upper right corner of the OSD Window; or press [**Esc**].
- ◆ To Logout, click **F8** or the **ZZ** symbol at the top of the Main Screen, or press [**F8**].
- ◆ To move up or down through the list one line at a time, Click the Up and Down Triangle symbols (**▲▼**) or use the Up and Down Arrow Keys. If there are more list entries than there is room for on the Main Screen, the screen will scroll.
- ◆ To move up or down through the list one screen at a time, Click the Up and Down Arrow symbols (**↑↓**), or use the [Pg Up] and [Pg Dn] keys. If there are more list entries than there is room for on the Main Screen, the screen will scroll.
- ◆ To bring the KVM focus to a port, Double Click it, or move the Highlight Bar to it then press [Enter].

Note: 1. If you try to access a computer that has been designated as private (see *PRIVATE MODE*, page 23), a message appears to inform you that the *Port is in Private Mode*. In this case, the screen is blank, and the port can neither be viewed, nor accessed.

2. If you try to access a computer that is already being accessed by another Console, a message displays to inform you that the *Port is In Use*. The target computer's screen can be viewed, but you cannot give it any input until the Console that already has control stops accessing it.

3. In a cascaded installation, if a computer attached to a Second Stage switch is already being accessed by another Console, that computer and all the other computers attached to the same Second Stage unit are considered to be in use. None of them can be viewed or accessed from your Console. This is so, because accessing any one computer attached to a Second Stage unit ties up the entire CS428 Port that the unit is cascaded down from. Only after the original Console no longer has access - either because it relinquishes access, or because the timeout delay (see *SET LOGOUT TIMEOUT*, page 21), has been exceeded - can these computers be controlled from another Console.

- ◆ After executing any action, you automatically go back to the menu one level above.

OSD Main Menu Headings

Heading	Explanation
PN	This column lists the Port Numbers for all the KVM Ports. The simplest method to access a particular computer (assuming you know which port it is attached to), is to Double Click it with the Mouse; or to use the Navigation Keys to move the Highlight Bar to it, then press [Enter] .
	Indicates ports that this Console can access. This Console cannot access ports that do not have this symbol displayed. Permission for a particular Console to be able to access a port is granted by the Administrator (see <i>SET ACCESSIBLE PORTS</i> , page 21).
QV	An <i>arrowhead</i> symbol in this column indicates the Port has been selected for Quick View Scan Mode (see <i>F7 QV</i> , page 24).
PC	A <i>sun</i> symbol in this column indicates that the computer connected to this Port is powered On, and is On Line.
NAME	If a port has been given a name (see <i>F2 EDIT.</i> , page 17), its name appears in this column.

OSD Functions

OSD functions are used to configure and control the OSD. For example, you can: rapidly switch to any port; scan selected ports only; limit the list you wish to view; designate a port for Quick View scanning; create or edit a port name; or make OSD setting adjustments.

To access an OSD function:

1. Either Click a Function Key field on the screen, or press a Function Key on the keyboard.
2. In the Submenus that appear make your choice either by Double Clicking it, or moving the Highlight Bar to it.
3. Press **[Esc]** to activate your choice and return to the previous menu level.

F1 HELP:

Help provides a quick guide to OSD operation. To return to the OSD Main Menu, Click the **X** at the upper right corner of the OSD Window; or press **[Esc]**.

F2 EDIT:

This is an Administrator function. To help remember which computer is attached to a particular port, every port can be given a name. The Edit function allows the Administrator to create, modify, or delete port names. To Edit a port name:

1. Click the port you want, or use the Navigation Keys to move the highlight bar to it.
2. Click the F2 field, or Press **[F2]**.
3. Key in the new Port Name, or modify/delete the old one.

The maximum number of characters allowed for the Port Name is 15.

Legal characters include:

- ◆ All alpha characters: a - z; A - Z
- ◆ All numeric characters: 0 - 9
- ◆ +, -, /, ., and [Space]

Case does not matter; OSD displays the Port Name in all capitals no matter how they were keyed in.

4. When you have finished editing, press **[Enter]** to have the change take effect. To abort the change, press **[Esc]**.

F3 LIST:

This function lets you broaden or narrow the scope of which ports the OSD lists. This will be different for each Console, depending on the choices made for that Console. The choices and their meanings are given in the table, below:

Choice	Meaning
ALL	Lists the Port Numbers and Names (if names have been specified - see <i>F2 EDIT</i> ., page 17), of all the ports on the installation.
QVIEW	Lists only the ports that have been selected for Quick View scanning (see <i>F7 QV</i> , page 24).
POWERED ON	Lists only the ports that have their attached computers Powered On.
POWERED ON + QVIEW	Lists only the ports that have been selected for Quick View scanning (see <i>F4 SCAN</i> ., page 19), and that have their attached computers Powered On.
QVIEW + NAME	Lists only the ports that have been selected for Quick View scanning (see <i>F7 QV</i> , page 24), and have been assigned names (see <i>F2 EDIT</i> ., page 17).
NAME	Lists only the ports that have been assigned names (see <i>F2 EDIT</i> ., page 17).

Double Click the choice you want, or move the Highlight Bar to it then press **[Enter]**. An icon appears before the choice to indicate that it is the currently selected one.

-
- Note:** 1. You can access any port on any list by Double Clicking it, or using the Navigation Keys then pressing **[Enter]**.
2. If you select a port that does not have a computer attached to it, or if the attached computer is powered Off, the OSD will still switch to it, and will not show an error. To recover, press the OSD Activation Hotkey (see *OSD Overview*, page 13).
-

F4 SCAN:

Clicking the F4 field, or pressing [F4] initiates *Scan Mode*, in which the OSD cycles through all the ports that have been selected for scanning with the *Scan Mode* setting (see *SCAN MODE*, page 22). When you want to stop at a particular location, press the [Spacebar] to stop scanning.

- ◆ If the scanning stops on an empty port, or one where the computer is attached but is powered Off, the monitor screen will be blank and the mouse and keyboard will have no effect. To recover, To recover, press the OSD Activation Hotkey.
- ◆ As the OSD cycles through the selected ports, an **[S]** appears in front of each accessed computer's Port ID display to indicate that the computer is being accessed under Quick View Scanning.
- ◆ If a particular port is being accessed by another Console, an **[R]** appears in front of the Port ID display to indicate that the Port is "View Only." It can be viewed, but cannot be accessed at this time.
- ◆ If a particular port has been designated as private (see F6, below), a **[P]** appears in front of the Port ID display to indicate that the Port is in "Private Mode." The screen is blank, and the port can neither be viewed, nor accessed.
- ◆ If a particular port was accessed by one of the Consoles, but is no longer being accessed, the OSD begins a Timeout countdown (see *Set Access Timeout* and *Set Logout Timeout* in the table, below), a **[Z]** appears in front of the Port ID display to indicate that the Port is Pending (i.e., the original Console that accessed it has first priority to reclaim it, but when the Timeout period ends, it is up for grabs to the first comer).

F5 ADM:

F5 allows an Administrator to configure the OSD operation of the Console. To change a setting Double Click it; or use the Up and Down Arrow Keys to move the highlight bar to it then press **[Enter]**.

-
- Note:**
1. To avoid Administrator conflict, a priority system has been set up in which, by default, Console 1 has priority over anything attached to Port 1; Console 2 has priority over anything attached to Port 2; Console 3 has priority over anything attached to Port 3; and Console 4 has priority over anything attached to Port 4.
 2. Only one Administrator may access the F5 ADM (Administrator) function at a time. If a second Administrator attempts to access the F5 function while it is already being accessed, he is denied access, and a message appears on screen to inform him of the rejection.
-

After you select an item, a submenu with further choices for you to select from appears. Double Click the choice you want, or move the Highlight Bar to then press **[Enter]**. An icon appears before the selected choice so that you know which one it is. The settings are explained in the following table:

Setting	Function
SET PASSWORD	<p>This function is used to set passwords for the Administrator and User:</p> <ol style="list-style-type: none"> 1. One Administrator and four User passwords can be set. 2. Move the highlight bar to User or Administrator, then press [Enter]. A screen that allows you to key in your password appears. The password may be up to 8 characters long, and can consist of any combination of letters and numbers (A - Z, 0 - 9). 3. Key in the new password, then press [Enter]. You are asked to key the password in again, in order to confirm that it is correct. 4. Key in the new password again, then press [Enter]. If the two entries match, the new password is accepted. If the entries do not match, you must start again from the beginning. 5. To modify or delete a previous password, use the backspace key to erase individual letters or numbers. 6. If the Administrator wants to change a User's password, he must enter his Administrator's password first.

Setting	Function
SET ACCESSIBLE PORTS	This function allows Administrators and Users to select which Ports can be accessed from a particular Console. Move the highlight bar to the target computer, then press [Enter] or the [Spacebar] to toggle access On and Off. If access is On, a plus mark (+) appears to indicate so. If access is Off, the area is blank. Make your choice, then press [Esc] to confirm.
SET MULTIUSER MODE	<p>This function determines whether or not the same ID can be used to log into the CS428 from different Consoles at the same time.</p> <ol style="list-style-type: none"> 1. If Disabled, the same ID cannot be used; if Enabled (the default), the same ID can be used to log in from more than one Console. 2. If Enabled, the F4, F6, and F7 settings set for any one Console, will be the same for all other Consoles that log in with the same ID. 3. Changes made to the F4, F6, and F7 settings by any logged in Console will automatically affect all Consoles with the same ID.
SET ACCESS TIMEOUT	This function is used to set the timeout value to control the release of access rights to a computer. If the original Console doesn't access the computer before the timeout value is reached, the computer becomes available to the other Consoles. To set the timeout value, key in a number from 2 - 255 seconds, then press [Enter] (if the number is 0 [zero], this function is disabled. Default is 010 (ten) seconds.
CLEAR THE NAME LIST	This function clears the port name list.
RESTORE DEFAULT VALUES	This function is used to undo all Administrator changes and return the setup to the original factory default settings - except for the Names that were assigned to Ports, which are saved.
RELEASE ALL PRIVATE	Releases all Ports that have been set to Private Mode (see <i>PRIVATE MODE</i> , page 23), so that they become accessible to all Consoles.
SET LOGOUT TIMEOUT	If a Console that has accessed a computer isn't used for the amount of time set with this function, the Operator is automatically logged out. A login is necessary before the Console can be used again. This enables the other Consoles to gain access to the computers when the original Console is no longer accessing them, but the Operator has forgotten to relinquish access. To set the timeout value, key in a number from 1 - 255 minutes, then press [Enter] If the number is 0 [zero], this function is disabled. Default is 5 (five) minutes.

F6 Set:

[F6] allows you to configure the OSD settings for the Console you are working at. To change a setting:

1. Double Click it; or move the highlight bar to it, then press **[Enter]**
2. Press **[Esc]** to activate it.

After you select an item, a submenu with further choices appears. To make a selection, either Double Click it; or move the Highlight Bar to it, then press **[Enter]**. An icon appears before the selected choice to indicate which one it is. The settings are explained in the table below:

Setting	Function
OSD ACTIVATING HOTKEY	Selects which Hotkey activates the OSD function: [Ctrl] [Ctrl] (the default) or [Scroll Lock] [Scroll Lock] . The Scroll Lock option is provided in case the Ctrl key combination conflicts with programs running on the computers.
CHANNEL DISPLAY MODE	Selects how the Port ID is displayed: the Port Number plus the Name (PN + NAME); the Port Number alone (PN); or the Name alone (NAME).
CHANNEL DISPLAY DURATION	Determines how long a Port ID displays for after a port change has taken place. The choices are: User Defined - which lets you select the amount of time that the Port ID displays for after a port change has taken place (from 1 - 255 sec.); and Display Always On - which displays the Port ID at all times. If you select <i>User Defined</i> , key in the number of seconds, then press [Enter] . The default is 3 Seconds.
CHANNEL DISPLAY POSITION	Allows you to position where the Port ID appears on the screen. Highlight this item, then press [Enter] ; use the Mouse or the Arrow Keys to position the Port ID display, then Double Click or press [Enter] to lock the position and return to the <i>Set</i> submenu.
SCAN MODE	Selects which Ports are available for scanning. There are six choices: <ul style="list-style-type: none"> ◆ ALL - All the Ports which have been set Accessible (F5) ◆ QVIEW - Only those Ports which have been set Accessible (F5) and have been selected for Quick View Scanning (F7) ◆ POWERED ON - Only those Ports which have been set Accessible (F5) and are Powered On ◆ POWERED ON + QVIEW - Only those Ports which have been set Accessible (F5) and have been selected for Quick View Scanning (F7) and are Powered On ◆ QVIEW + NAME - Only those Ports which have been set Accessible (F5) and have been selected for Quick View Scanning (F7) and have been named (F2) ◆ NAME - Only those Ports which have been set Accessible (F5) and have been named (F2).

(Continued from previous page.)

Setting	Function
SCAN DURATION	Determines how long the display dwells on each port when it cycles through the selected ports in <i>Quick View Scan Mode</i> . Key in a value from 1 - 255 seconds, then press [Enter] . Default is 3 seconds.
PRIVATE MODE	The [Enter] key is a toggle that Enables/Disables Private Mode for the currently selected port. When Private Mode is Enabled, none of the other Consoles cannot access the port, and their monitors show a blank screen when they come to it. If another console tries to access the port, the message: Private Mode: Console x (where x represents the number of the console that has set private mode for the port), displays on its screen. When you have finished making your selections, press [Esc] to return to the OSD Main Menu.
RESTORE DEFAULT VALUES	This function is used to undo all User changes and return the setup to the original factory default settings - except for the Names that were assigned to Ports, which are retained.
MOUSE BUTTON SETUP	This function allows you to set the mouse for right or left handed operation. Use [Enter] to toggle between the two.
SET PASSWORD	This function is for Users to set their passwords: <ol style="list-style-type: none"> 1. When you access this function, if you already have a password you must enter it in order to continue. 2. A screen appears that allows you to key in your new password. The password may be up to 8 characters long, and can consist of any combination of letters and numbers (A - Z, 0 - 9). 3. To modify or delete a previous password, use [Backspace] to delete the characters. 4. Key in the password, then press [Enter]. You are asked to key the password in again, in order to confirm that it is correct. Key in the new password again, then press [Enter]. <p>If the two entries match, the new password is accepted. If the entries do not match, you must start again from the beginning.</p>

F7 QV

You can broaden or narrow the number of ports that get automatically scanned by selecting only the ones you want with the QV (Quick View Scan) function. [F7] is a toggle that selects or deselects the currently highlighted port for the Quick View Scanning function (see F4, above). To select/deselect a port for Quick View Scanning:

1. Double Click the port you want, or use the Navigation Keys to move the highlight bar to it.
2. Press [F7].

When a port has been selected for Quick View Scanning, an arrowhead displays in the QV column to indicate so. When a port is deselected, the arrowhead disappears.

F8 Out

Clicking the F8 field, or pressing [F8] logs you out of OSD control of the computers, and blanks the Console screen. This is different from simply pressing [Esc] to deactivate the OSD, since with this function you must log in all over again to regain access to the OSD.

Note: When you reenter the OSD after logging out, the screen stays blank except for the OSD Main Menu. You must input your password before you can continue.

Safety Instructions

General

- ◆ Read all of these instructions. Save them for future reference.
- ◆ Follow all warnings and instructions marked on the device.
- ◆ Do not place the device on any unstable surface (cart, stand, table, etc.). If the device falls, serious damage will result.
- ◆ Do not use the device near water.
- ◆ Do not place the device near, or over, radiators or heat registers.
- ◆ The device cabinet is provided with slots and openings to allow for adequate ventilation. To ensure reliable operation, and to protect against overheating, these openings must never be blocked or covered.
- ◆ The device should never be placed on a soft surface (bed, sofa, rug, etc.) as this will block its ventilation openings. Likewise, the device should not be placed in a built in enclosure unless adequate ventilation has been provided.
- ◆ Never spill liquid of any kind on the device.
- ◆ Unplug the device from the wall outlet before cleaning. Do not use liquid or aerosol cleaners. Use a damp cloth for cleaning.
- ◆ The device should be operated from the type of power source indicated on the marking label. If you are not sure of the type of power available, consult your dealer or local power company.
- ◆ The device is equipped with a 3-wire grounding type plug. This is a safety feature. If you are unable to insert the plug into the outlet, contact your electrician to replace your obsolete outlet. Do not attempt to defeat the purpose of the grounding-type plug. Always follow your local/national wiring codes.
- ◆ Do not allow anything to rest on the power cord or cables. Route the power cord and cables so that they cannot be stepped on or tripped over.
- ◆ If an extension cord is used with this device make sure that the total of the ampere ratings of all products used on this cord does not exceed the extension cord ampere rating. Make sure that the total of all products plugged into the wall outlet does not exceed 15 amperes.

- ◆ To help protect your system from sudden, transient increases and decreases in electrical power, use a surge suppressor, line conditioner, or un-interruptible power supply (UPS).
- ◆ Position system cables and power cables carefully; Be sure that nothing rests on any cables.
- ◆ When connecting or disconnecting power to hot-pluggable power supplies, observe the following guidelines:
 - ◆ Install the power supply before connecting the power cable to the power supply.
 - ◆ Unplug the power cable before removing the power supply.
 - ◆ If the system has multiple sources of power, disconnect power from the system by unplugging all power cables from the power supplies.
- ◆ Never push objects of any kind into or through cabinet slots. They may touch dangerous voltage points or short out parts resulting in a risk of fire or electrical shock.
- ◆ Do not attempt to service the device yourself. Refer all servicing to qualified service personnel.
- ◆ If the following conditions occur, unplug the device from the wall outlet and bring it to qualified service personnel for repair.
 - ◆ The power cord or plug has become damaged or frayed.
 - ◆ Liquid has been spilled into the device.
 - ◆ The device has been exposed to rain or water.
 - ◆ The device has been dropped, or the cabinet has been damaged.
 - ◆ The device exhibits a distinct change in performance, indicating a need for service.
 - ◆ The device does not operate normally when the operating instructions are followed.
- ◆ Only adjust those controls that are covered in the operating instructions. Improper adjustment of other controls may result in damage that will require extensive work by a qualified technician to repair.

Rack Mounting

- ◆ Before working on the rack, make sure that the stabilizers are secured to the rack, extended to the floor, and that the full weight of the rack rests on the floor. Install front and side stabilizers on a single rack or front stabilizers for joined multiple racks before working on the rack.
- ◆ Always load the rack from the bottom up, and load the heaviest item in the rack first.
- ◆ Make sure that the rack is level and stable before extending a device from the rack.
- ◆ Use caution when pressing the device rail release latches and sliding a device into or out of a rack; the slide rails can pinch your fingers.
- ◆ After a device is inserted into the rack, carefully extend the rail into a locking position, and then slide the device into the rack.
- ◆ Do not overload the AC supply branch circuit that provides power to the rack. The total rack load should not exceed 80 percent of the branch circuit rating.
- ◆ Ensure that proper airflow is provided to devices in the rack.
- ◆ Do not step on or stand on any device when servicing other devices in a rack.

Technical Support

International

Email Support	Email your questions and concerns to: support@aten.com
Online Support ♦ Technical Support ♦ Troubleshooting ♦ Documentation ♦ Software Updates	<ol style="list-style-type: none"> 1. Online technical support is available to ALTUSEN customers through our e-Support Center: http://support.aten.com 2. Online troubleshooting that describes the most commonly encountered problems and offers possible solutions to them; online documentation (including electronically available manuals); and the latest drivers and firmware for your product are available at our website: http://www.aten.com
Telephone Support	886-2-8692-6959

North America

Email Support	Email your questions and concerns to: support@aten-usa.com
Online Support ♦ Technical Support ♦ Troubleshooting ♦ Documentation ♦ Software Updates	<ol style="list-style-type: none"> 1. Online technical support is available to ALTUSEN customers through our e-Support Center: http://www.aten-usa.com/support 2. Online troubleshooting that describes the most commonly encountered problems and offers possible solutions to them; online documentation (including electronically available manuals); and the latest drivers and firmware for your product are available at our website: http://www.aten-usa.com
Telephone Support	1-888-999-ATEN

When you contact us, please have the following information ready beforehand:

- ♦ Product model number, serial number, and date of purchase.
- ♦ Your computer configuration, including operating system, revision level, expansion cards, and software.
- ♦ Any error messages displayed at the time the error occurred.
- ♦ The sequence of operations that led up to the error.
- ♦ Any other information you feel may be of help.

Master View - Computer Connection Tables

Switches	Type	Computers
1	CS428	1 - 8
2	CS-128A / CS-138A / CS-9138	8 - 15
3	CS-128A / CS-138A / CS-9138	15 - 22
4	CS-128A / CS-138A / CS-9138	22 - 29
5	CS-128A / CS-138A / CS-9138	29 - 36
6	CS-128A / CS-138A / CS-9138	36 - 43
7	CS-128A / CS-138A / CS-9138	43 - 50
8	CS-128A / CS-138A / CS-9138	50 - 57
9	CS-128A / CS-138A / CS-9138	57 - 64

Switches	Type	Computers
1	CS428	1 - 8
2	CS-124A	8 - 11
3	CS-124A	11 - 14
4	CS-124A	14 - 17
5	CS-124A	17 - 20
6	CS-124A	20 - 23
7	CS-124A	23 - 26
8	CS-124A	26 - 29
9	CS-124A	29 - 32

Specifications

Function		Specification	
Computer Connections	Direct	8	
	Max	64 (via Cascade)	
Port Selection		OSD (On Screen Display)	
Connectors	Console 1 & 2	Keyboard	2 x 6-pin Mini DIN Female (Purple)
		Video	2 x HDB-15 Female
		Mouse	2 x 6-pin Mini DIN Female (Green)
		Speaker	2 x Mini Stereo Jack Female (Green)
		Microphone	2 x Mini Stereo Jack Female (Pink)
	Console 3 & 4		2 x 25-pin D Type Female
	KVM Ports		8 x 25-pin D Type Female
Power		1 x DC Jack	
Switches	Reset	1 x Semi-recessed Pushbutton	
LEDs	On Line	8 (Orange)	
	Selected	8 (Green)	
	Power	1 (Blue)	
Emulation	Keyboard	PS/2 and PC/AT	
	Mouse	PS/2 and Serial	
Video		1920 x 1440; DDC2	
Power Consumption		DC 9V; 7.2W (max.)	
Environment	Operating Temp.	5 - 40° C	
	Storage Temp.	-20 - 60° C	
	Humidity	0 - 80% RH	
Physical Properties	Housing	Metal	
	Weight	4.2 kg	
	Dimensions (L x W x H)	43.35 x 25.42 x 4.4 cm (19" / 1U)	

OSD Factory Default Settings

Setting	Function
MULTIUSER MODE	Enabled
ACCESS TIMEOUT	10 Seconds
OSD HOTKEY	[Ctrl] [Ctrl]
DISPLAY MODE	The Port Number plus the Port Name
DISPLAY DURATION	3 Seconds
SCAN DURATION	3 Seconds

Power On Self Test

When you turn the unit On, it undergoes a Power On Self Test. If there is a problem, Port LEDs 1 - 4 flash repeatedly according to a pattern that indicates what the problem is:

Pattern	Indication
On Line LEDs 1 - 8 Flash Simultaneously	Internal RAM Memory Error
On Line LEDs 1 - 8 Flash One After the Other	External RAM Memory Error
On Line LED pairs 1+2, 3+4, 5+6, and 7+8 Flash One After the Other	ROM Test Error

If any of these problems occur, turn the Switch Off, then turn it On again.

Troubleshooting

Symptom	Possible Cause	Action
Keyboard and/or Mouse not responding.	The connection from the selected port to the target computer has been broken, or the computer is turned OFF.	Check the Online LED for the selected port. If it is not lit: <ol style="list-style-type: none">1. Check to see that the computer is powered On.2. Check the cables to make sure they are all properly connected.
	Keyboard/Mouse need to be reset.	<ol style="list-style-type: none">1. Unplug the keyboard and/or Mouse connector from the Console Keyboard and/or Mouse Ports, then plug it/them back in.2. Use a thin object (such as the end of a paper clip, or a ballpoint pen), to press the K/M Reset Switch (located on the front panel), in.

Limited Warranty

IN NO EVENT SHALL THE DIRECT VENDOR'S LIABILITY EXCEED THE PRICE PAID FOR THE PRODUCT FROM DIRECT, INDIRECT, SPECIAL, INCIDENTAL, OR CONSEQUENTIAL DAMAGES RESULTING FROM THE USE OF THE PRODUCT, DISK, OR ITS DOCUMENTATION.

The direct vendor makes no warranty or representation, expressed, implied, or statutory with respect to the contents or use of this documentation, and especially disclaims its quality, performance, merchantability, or fitness for any particular purpose.

The direct vendor also reserves the right to revise or update the device or documentation without obligation to notify any individual or entity of such revisions, or update. For further inquiries, please contact your direct vendor.

C

- Cables, 3
- Components
 - Front Panel, 4
 - Rear Panel, 5
- Connection Tables, 29

F

- Factory Default Settings, 31
- Features, 2

H

- Hot Plugging, 11

I

- Installation
 - Cascaded, 9
 - Single Station, 8

L

- Limited Warranty, 32

M

- Mounting, 7

O

- Online
 - Registration, iii
- OSD
 - Factory Default Settings, 31
 - Functions, 16
 - Main Menu Headings, 16
 - Navigation, 15
 - Overview, 13
- Overview, 1

P

- Package Contents, iv
- Port Numbering, 12
- Port Selection, 12
- Power On Self Test, 31
- Powering Off and Restarting, 11

R

- Rack Mounting, 7
 - Safety information, 27
- Requirements
 - Cables, 3
 - Computers, 3
 - Console, 3
- RoHS, ii

S

- Safety Instructions
 - General, 25
 - Rack Mounting, 27
- SJ/T 11364-2006, ii
- Specifications, 30
- Stacking, 7
- System Requirements
 - Computers, 3

T

- Technical Support, 28
- Telephone support, iii
- Troubleshooting, 32

U

- User Notice, iii